

# Orbit 20 Pro Floor Finisher Parts and Instruction Manual



**PREFACE**

Thank you for your purchase of the new industry standard for scrubbers. Minuteman International takes great pride in offering the most dependable, reliable and best value in industrial power sweepers and sweeper / scrubbers. We set the standard.

Our Customer Service Department would like to hear from you. If you see any errors, omissions or something that needs clarification in this Parts Catalog please let us know. We are working hard towards continually improving our processes to bring you the best you deserve. Please copy the form below, fill out and comment on how you found our catalog.

Thank you!  
*The Minuteman International Team*

Name: \_\_\_\_\_

Title: \_\_\_\_\_

Company Name: \_\_\_\_\_

Address: \_\_\_\_\_

Country: \_\_\_\_\_

Type of equipment or model number: \_\_\_\_\_

Comments: \_\_\_\_\_

\_\_\_\_\_

\_\_\_\_\_

\_\_\_\_\_

Please return to:  
Customer Service Manager  
Minuteman International, Inc.  
14N845 U.S. Route 20  
Pingree Grove, Illinois 60140 USA

Phone: (800) 323-9420  
Email: [tech@minutemanintl.com](mailto:tech@minutemanintl.com)

**Technical Specifications**

**Model**            **Orbit 20 Pro**  
 Model:            R20

<b>SPECIFICATIONS</b>	<b>R20</b>
PAD SIZE	20" X 14"
PAD DRIVER TYPE	COMBINATION PAD HOLDER/DIAMOND PAD DRIVER
POWER SOURCE	115V 60HZ
MOTOR/HP	1.0 HP TEFC 1740 RPM
AMP DRAW	7.8
VIBRATION COMPENSATOR	1.25
CORD	50' 14-3 SJT
PAD PRESSURE (lbs/in <sup>2</sup> )***	.40
TOTAL WEIGHT **	162
SHIPPING WEIGHT	198
**WEIGHT IS CALCULATED WITHOUT THE POWER CORD *** PAD PRESSURE DOES NOT INCLUDE THE WEIGHT OF THE POWER CORD.	

**For Safety When Servicing or Maintaining Machine**

- Stop on level surface.
- Unplug the machine.
- Avoid moving parts. Do not wear loose jackets, shirts, or sleeves when working on machine.
- Do not clean machine with a pressure washer.
- Authorized personnel must perform repairs and maintenance. Use Minuteman supplied replacement parts.

## Table of Contents

Technical Specifications .....	3
For Safety When Servicing or Maintaining Machine.....	3
Service Information.....	6
Features .....	7
Important Safety Instructions.....	8
Grounding Instructions .....	9
Basic Operation .....	10
Guidelines for Operation.....	11
Handle Adjustment .....	12
Cord Storage .....	13
Cleanup and Storage.....	13
Main Frame .....	14
Wheel Assembly .....	16
Handle Assembly.....	17
Handle Assembly (Continued).....	18
Parts List.....	20
Handle Wiring .....	24
Warranty .....	26



**Service Information**

To obtain consistent performance over the life of your equipment, read through these instructions and save them for future reference. If you require service, contact the dealer from which the machine was purchased or an authorized Minuteman representative. Always refer to your limited Warranty for complete service information. The model, type, and serial number are indicated on the data plate on the side of the handle. From prompt and complete service, refer to these numbers when inquiring about service

SERIAL NO.		MODEL
VOLTS	PHASE	HZ
MOTOR	AMPS	H.P.

<p>Write the model and serial number of your unit in the space provided. Refer to the data plate on unit.</p>	
SERIAL #	MODEL #
<p>Retain this owners manual for future reference.</p>	

## Features

- Twin (dual) capacitor 56-frame TEFC (totally enclosed fan cooled) motor keeps out dirt and dust for longer motor life.
- Extra heavy duty spring steel cord strain relief with a 50' 14-3 power cord
- Low current draw
- Thumb-operated safety switch
- Negative pressure on/off switch
- Dual steel operating triggers for left- or right-hand operation
- One-piece industrial powder coated heavy duty steel handle for optimum durability
- Welded frame for rugged, reliable performance
- Non-marking, 2x6" ball bearing wheels
- Multiple position handle adjustment for operator comfort and safety Comfortable vinyl handle grips for ease of use
- Full wraparound dust skirt

## Important Safety Instructions

When using an electrical appliance, basic precautions should always be followed, including the following:



### **WARNING:**

ELECTRIC SHOCK CAN CAUSE SERIOUS INJURY OR BE FATAL. PLEASE READ THE FOLLOWING INSTRUCTIONS ON THE USE AND OPERATIONS OF FLOOR FINISHING MACHINES.

- Your Orbit 20 Pro Floor Finisher is equipped with a safety switch lock and power switch triggers designed for your safety. Do not attempt to bypass or defeat the safety switch lock. Never use any device to lock the power switch triggers in the “ON” position.
- Do not leave the machine plugged in. Turn off the switch and unplug the electrical cord when not in use and before servicing or changing the brushes or pads.
- Do not allow the machine to be used as a toy. Close attention is necessary when used near children. Do not leave the machine connected to an electrical outlet unattended.
- Use only as described in this manual. Use only manufacturer’s recommended attachments.
- Do not use with a damaged cord or plug. If the machine is not working as it should, has been dropped, damaged, or left outdoors, return it to a service center before using.
- Use care to keep the electrical supply cord around sharp edges or corners. Keep the cord away from the heated surfaces.
- Connect to properly grounded (3-wire) outlet only. Refer to Grounding Instructions.
- Do not use extension cords or outlets with inadequate current carrying capacity.
- Turn off all controls before unplugging.
- Do not unplug by pulling on the cord. To unplug, grasp the plug and pull.
- Do not handle the plug or the machine with wet hands.
- Wind the cord no tighter than is necessary to retain it during storage. Refer to Cord Storage.
- Use extra care when working on or near stairs.
- Do not use in conjunction with flammable or combustible liquids such as gasoline, or use in areas where explosive vapor or dust may be present.
- Store your Orbit 20 Pro Floor Finisher indoors in a cool, dry area.
- Keep your work area well lighted.
- **WARNING:** To avoid electrical shock, use indoor only.





**WARNING:**

RISK OF EXPLOSION. FLOOR SANDING MACHINE CAN RESULT IN AN EXPLOSIVE MIXTURE OF FINE DUST AND AIR. USE FLOOR SANDING MACHINE ONLY IN A WELL-VENTILATED AREA, FREE FROM ANY FLAME OR MATCH

**Grounding Instructions**

This appliance must be grounded. If it should malfunction or break down, grounding provides a path of least resistance for electric current to reduce the risk of electric shock. This appliance is equipped with a cord that has an equipment-grounding conductor and grounding plug. The plug must be plugged into an appropriate outlet that is properly installed and grounded in accordance with all local codes and ordinances.

Improper connection of an equipment grounding conductor can result in risk of electric shock. Check with a qualified electrician or service person if you are in doubt as to whether the outlet is properly grounded. Do not modify the plug provided with the appliance. If it will not fit the outlet, have a proper outlet installed by a qualified electrician. This appliance is for use on a nominal 120 volt circuit and has a grounding plug that looks like the plug illustrated in Figure 1.

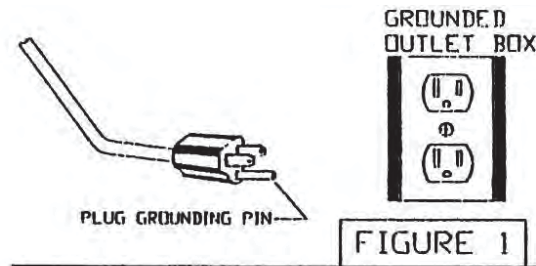

## Basic Operation

To turn the machine on, the operating handle must be lowered and locked to the proper operating position before switching the machine ON. Place both hands firmly on the handle grips with your fingers around the power triggers. Do NOT apply pressure on the triggers before the safety switch lock is disengaged.

Disengage the safety switch lock by pushing it forward with one thumb. Then, while holding the safety switch lock in the disengaged position, squeeze the power triggers toward the handle grips and return your thumb to the handle grip.



To stop the machine, simply release the triggers. The safety switch lock will automatically return to the engaged position.

## Guidelines for Operation

- Your Orbit 20 Pro Floor Finisher is a very sensitive, powerful unit. When in operation, it should be guided gradually and smoothly without sudden or rough motions. You will want to practice with your machine on a smooth surface until you have experience in operating it.
- For ease of operation, always keep the brush or pad surface level, balanced, and flat on the floor at all times.
- Always adjust the operating handle to a comfortable height at which the brush or pad surface is balanced before starting the machine. (See Handle Adjustment Page 4)
- Your machine will operate differently on various surfaces. For example, there will be much more resistance when the machine is used on a rough surface, than when it is used on a smooth surface. The operator should be prepared to adjust for these differences.
- Begin operating the machine with the pad surface level, balanced, and flat on the floor.
- To move the machine to the right, turn the unit to the right.
- To move the machine to the left, turn the unit to the left.
- To move the machine forward or backward, keep the brush or pad flat on the floor and push or pull the machine in the desired direction.

## Handle Adjustment

The handle can be adjusted to any desired work position by simply pulling on the pull pin and move the handle to the desired position. Firmly push the pull pin back into the adjustment holes. This will lock the handle in position.

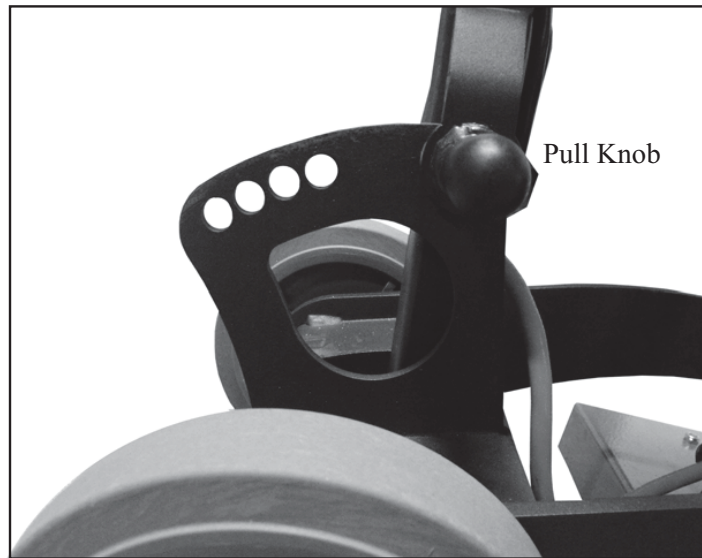

Figure 5

## Cord Storage

When not in use, loosely coil the power cord and hang on the handle.



## Cleanup and Storage

After being used, your Orbit 20 Pro Floor Finisher can be wiped clean with a soft damp cloth and should be stored in a clean, dry place.

**Main Frame**

**FRONT  
 VIEW**

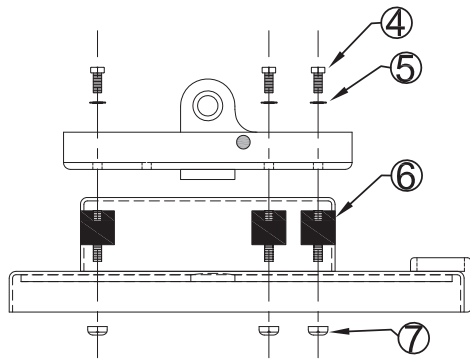
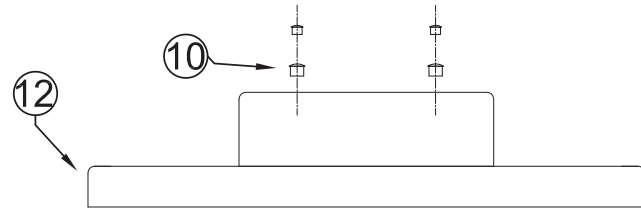

**SIDE VIEW  
 FRONT**

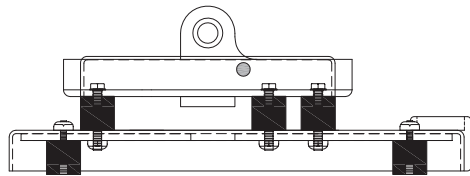

**SIDE VIEW  
 FRONT**

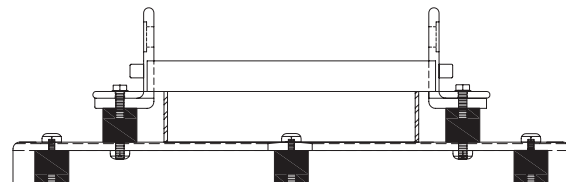
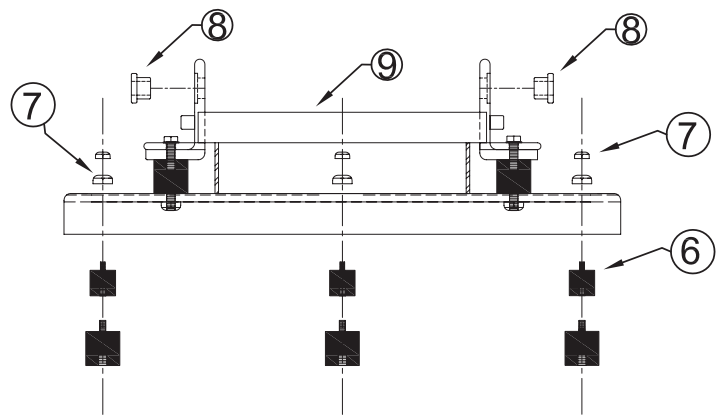
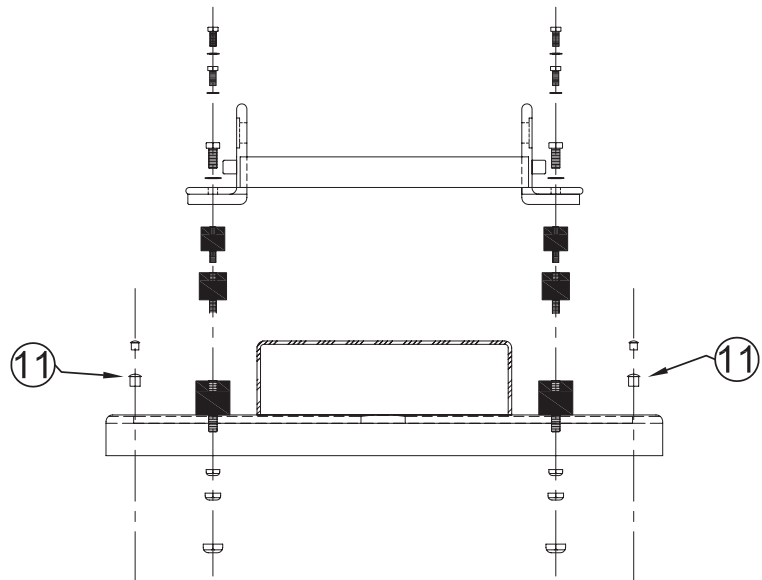

FRONT  
VIEW

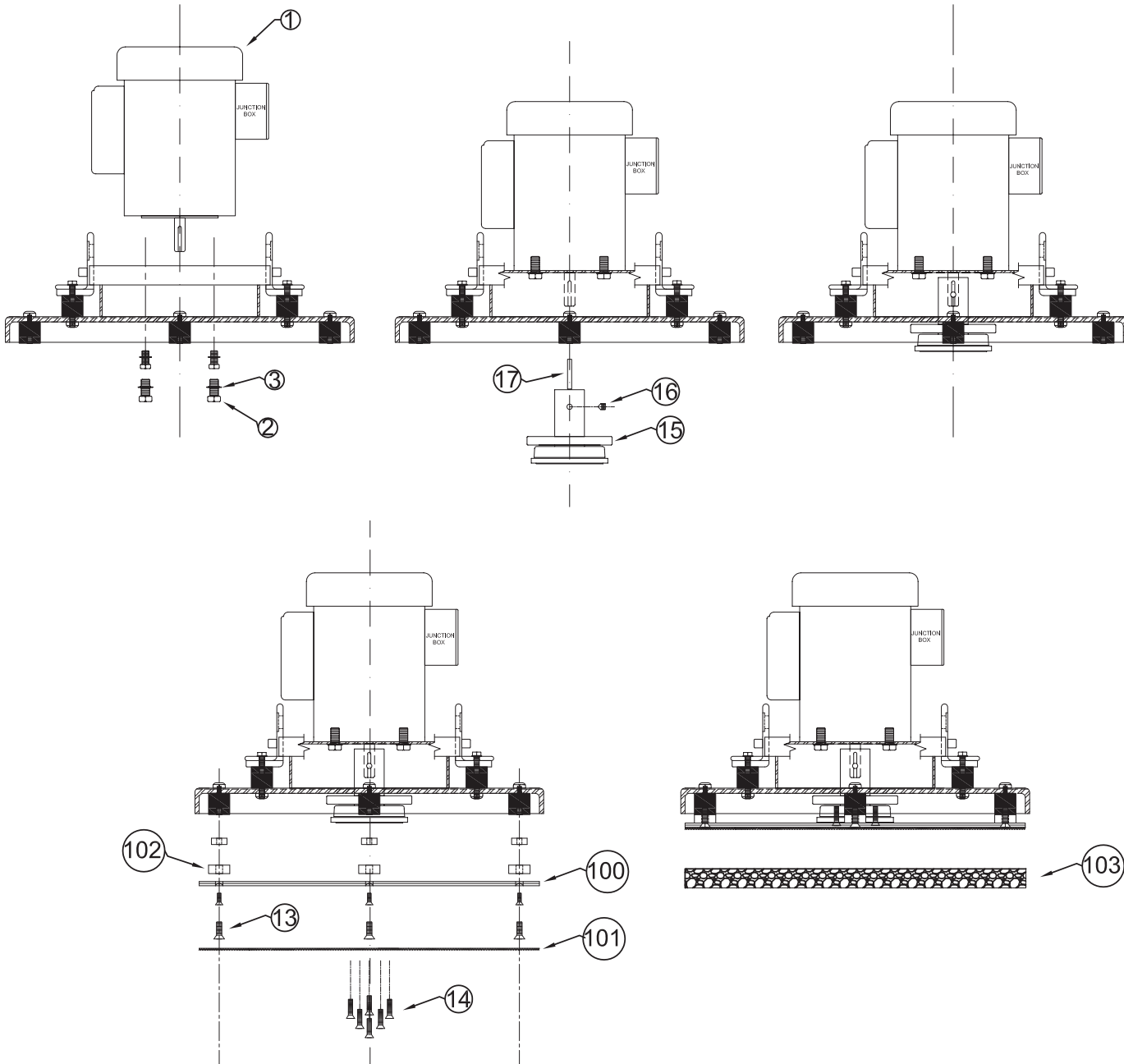

## Wheel Assembly

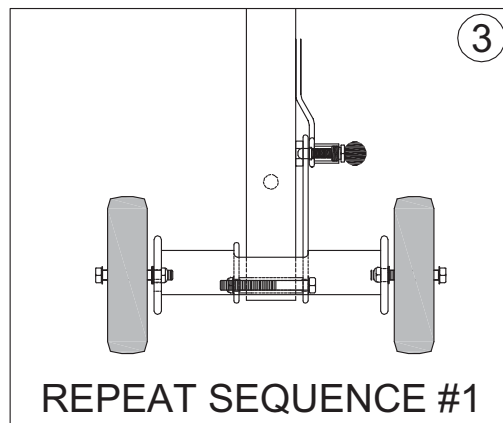
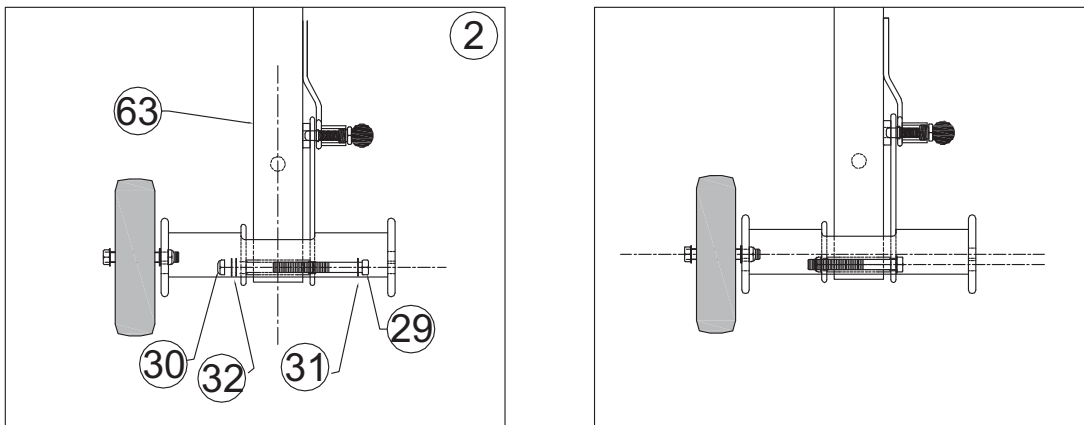
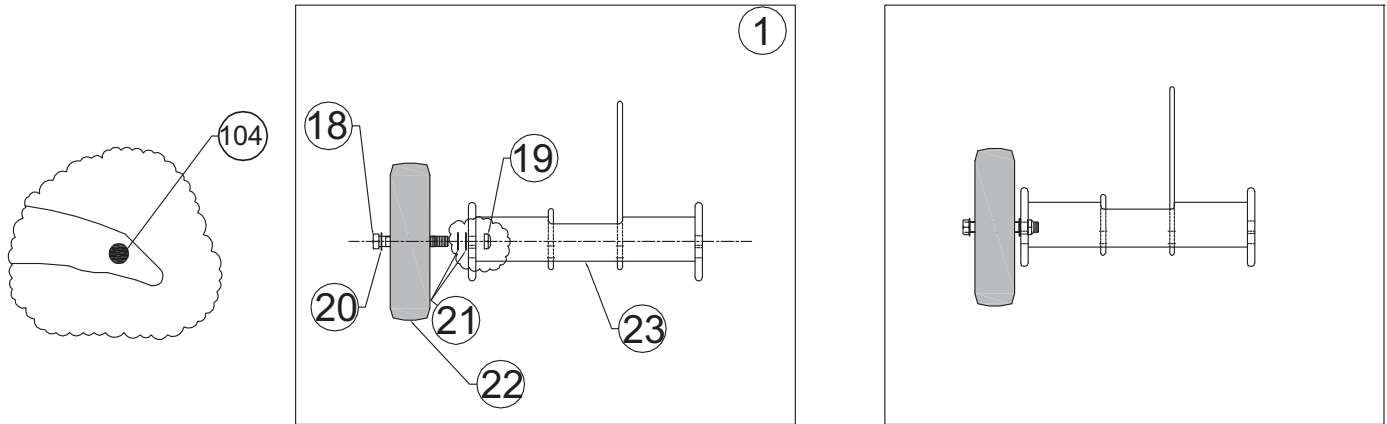



**Handle Assembly**

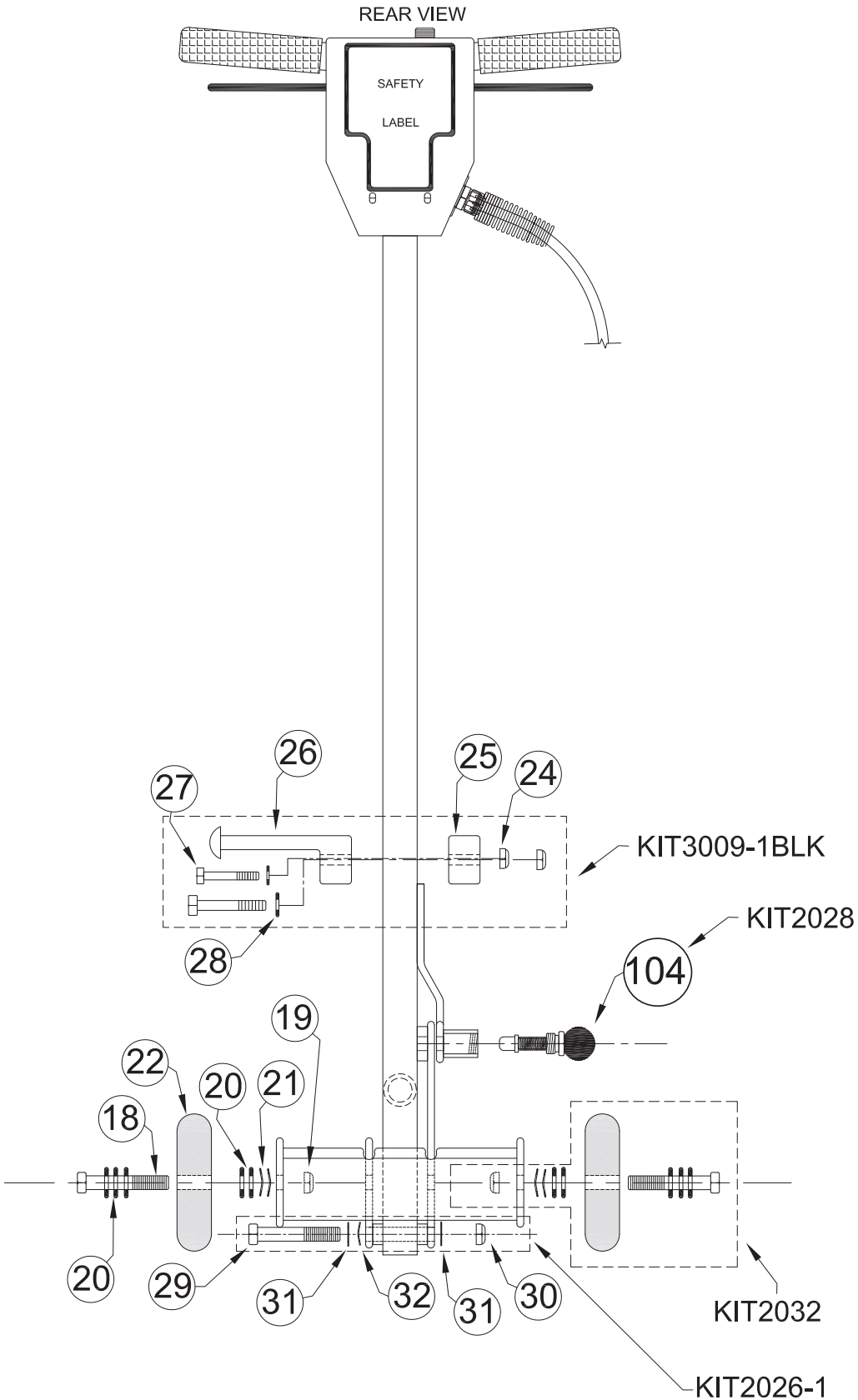

**Handle Assembly (Continued)**

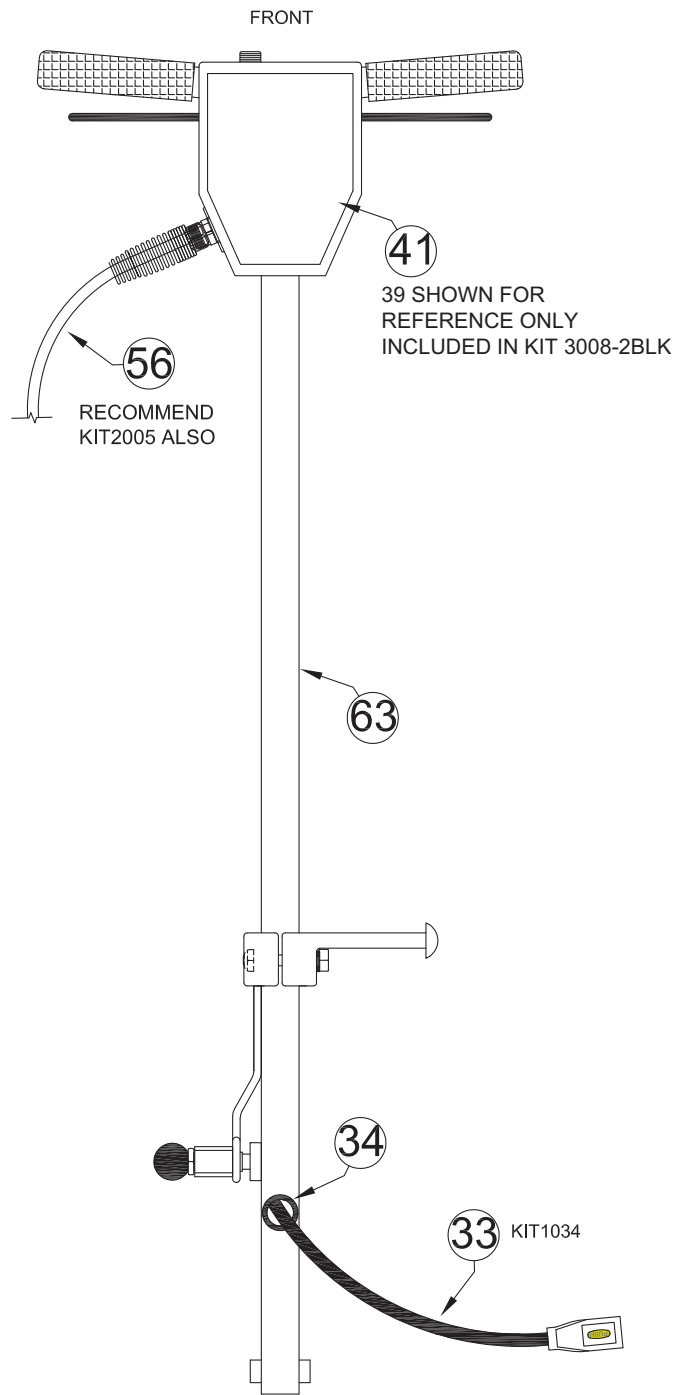

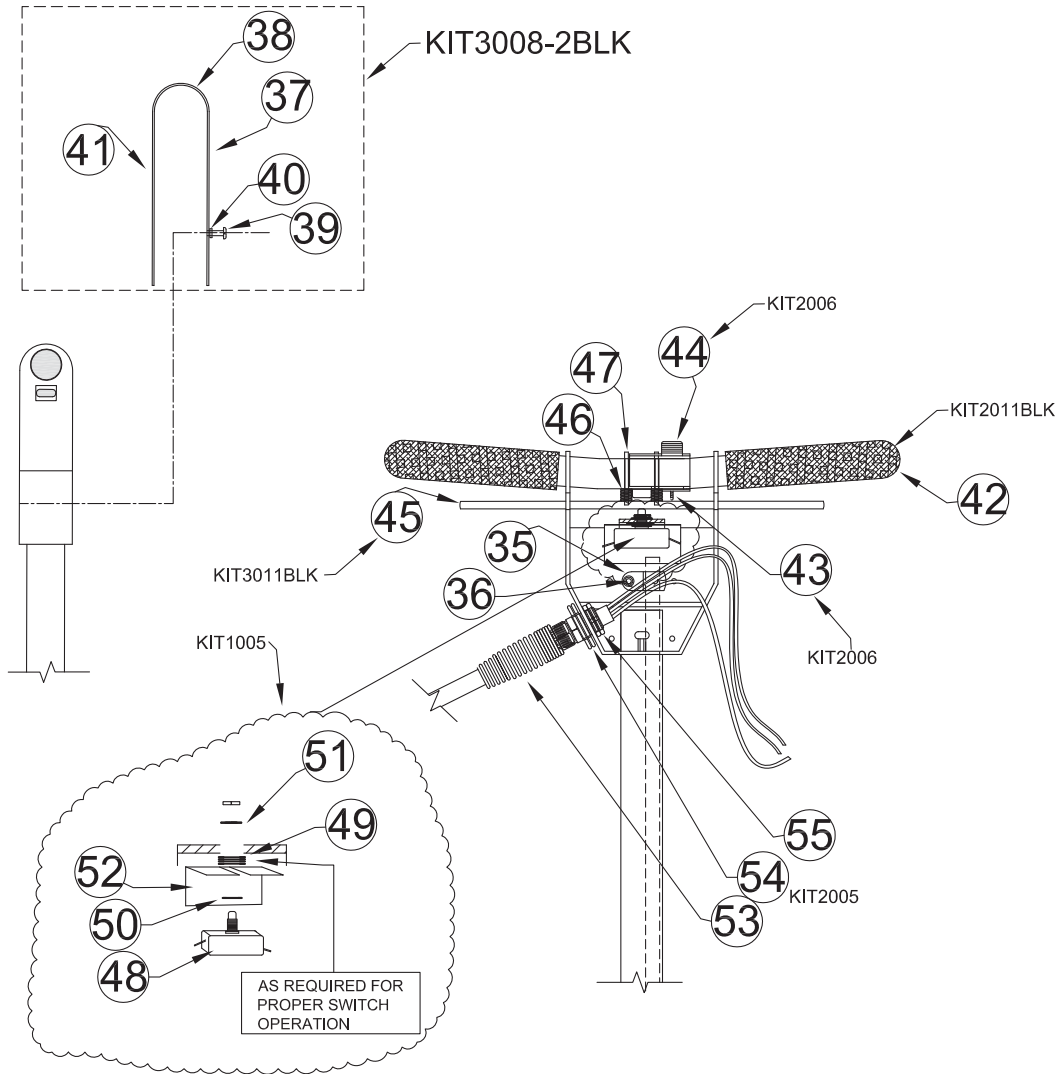

**Parts List**

Parts list			
ITEM	PART NO.	QTY	DESCRIPTION
	<b>KIT1042</b>		<b>MOTOR KIT</b>
1	INC IN KIT1042	1	MOTOR
2	INC IN KIT1042	4	BOLT
3	INC IN KIT1042	4	LOCKWASHER
	<b>KIT2037</b>		<b>SECONDARY ISOLATOR KIT</b>
4	INC IN KIT2037	6	BOLT
5	INC IN KIT2037	6	LOCKWASHER
6	INC IN KIT2037	6	ISOLATOR
7	INC IN KIT2037	6	NUT
	<b>KIT2036</b>		<b>SECONDARY ISOLATOR BRACKET KIT</b>
8	INC IN KIT2036	1	PIVOT BUSHING KIT (KIT2023)
9	INC IN KIT2036	1	SECONDARY ISOLATOR BRACKET
	<b>KIT2023</b>		<b>PIVOT BUSHING KIT</b>
8	INC IN KIT2023	2	BUSHINGS PIVOT NYLON
	<b>KIT2040</b>		<b>BUTTON PLUG KIT</b>
10	INC IN KIT2040	4	BUTTON PLUG 1/2 INCH
11	INC IN KIT2040	4	BUTTON PLUG
	<b>KIT3034RED</b>		<b>FRAME KIT MAIN</b>
10	INC IN KIT3034	1	BUTTON PLUG KIT 1/2 INCH
11	INC IN KIT3034	1	BUTTON PLUG KIT
12	INC IN KIT3034	1	MAIN FRAME
	<b>KIT2039</b>		<b>PRIMARY ISOLATOR KIT</b>
7	INC IN KIT2039	6	NUT
6	INC IN KIT2039	6	ISOLATOR
13	INC IN KIT2039	6	SCREW
14	INC IN KIT2039	6	ECCENTRIC SCREW
	<b>KIT2041</b>		<b>ECCENTRIC KIT</b>
15	INC IN KIT2041	1	ECCENTRIC -
16	INC IN KIT2041	1	SET SCREW
14	INC IN KIT2041	6	ECCENTRIC PAD DRIVER SCREWS
13	INC IN KIT2041	6	PAD DRIVER SCREWS
17	INC IN KIT2041	1	MOTOR KEY

Parts list			
ITEM	PART NO.	QTY	DESCRIPTION
	<b>KIT2038</b>		<b>PAD DRIVER KIT</b>
100	INC IN KIT2038	1	PAD DRIVER
101	INC IN KIT2038	1	PAD DRIVER FACE
102	INC IN KIT2038	6	NYLON SPACER
13	INC IN KIT2038	6	SCREWS PAD DRIVER
14	INC IN KIT2038	6	ECCENTRIC PAD DRIVER SCREWS
103	<b>KIT2047</b>		<b>BACKER PAD - RED</b>
	INC IN KIT2047	1	RED PAD 2014X1
	INC IN KIT2047	2	VELCRO
	<b>KIT2028</b>		<b>SPRING KNOB ASSY.</b>
104	INC IN KIT2028	1	KNOB ASSY
	<b>KIT2032</b>		<b>WHEEL KIT</b>
18	INC IN KIT2032	1	BOLT HEX .500-13 X 3
19	INC IN KIT2032	1	NUT HEX .500-13 NYLOC
20	INC IN KIT2032	5	FLAT WASHER
21	INC IN KIT2032	2	WASHER SPRING WAVE
22	INC IN KIT2032	1	WHEEL
	<b>KIT3031</b>		<b>CARRAGE FRAME</b>
23	INC IN KIT3031	1	CARRAGE FRAME (ONLY)
	<b>KIT3009-1BLK</b>		<b>CORD HOOK KIT (SQUARE)</b>
24	INC IN KIT3009-1BLK	2	NUT 3/8-16 NYLOCK
25	INC IN KIT3009-1BLK	1	CAP CORD HOOK SQUARE BLK
26	INC IN KIT3009-1BLK	1	CORD HOOK SQUARE BLK
27	INC IN KIT3009-1BLK	2	BOLT HEX 3/8-16 X 2
28	INC IN KIT3009-1BLK	2	WASHER FLAT BLK
	<b>KIT2026-1</b>		<b>HANDLE MOUNTING HWDR KIT</b>
29	INC IN KIT2026-1	1	BOLT HEX .500-13 X 3
30	INC IN KIT2026-1	1	NUT HEX .500-13 NYLOC
31	INC IN KIT2026-1	2	FLAT WASHER
32	INC IN KIT2026-1	2	WASHER SPRING WAVE

Parts list			
ITEM	PART NO.	QTY	DESCRIPTION
	<b>KIT1034</b>		<b>IN HANDLE CORD KIT</b>
33	INC IN KIT1034	1	IN HANDLE CORD
34	INC IN KIT1034	1	GROMMET IN HANDLE
35	INC IN KIT1034	1	LOOP CLAMP
36	INC IN KIT1034	1	SCREW 10-24 X .50 THIRD ROLL PHILL PAN ZINC
40	INC IN KIT1034	4	WASHER # 10 EXTERNAL TOOTH LOCK - ZINC
57	INC IN KIT1034	1	WIRE NUT
39	INC IN KIT1034	3	SCREW 10-24 X .50 THIRD ROLL PHILL PAN ZINC
	INC IN KIT1034	1	BUTTON PLUG (NOT SHOWN)
	<b>KIT3008-2BLK</b>		<b>SWITCH BOX ASSY KIT</b>
37	INC IN KIT3008-2BLK	1	WARNING SWITCH BOX SAFETY LABEL REAR
38	INC IN KIT3008-2BLK	1	SWITCH BOX COVER
39	INC IN KIT3008-2BLK	2	SCREW 10-24 X .50 THIRD ROLL PHILL PAN ZINC
40	INC IN KIT3008-2BLK	2	WASHER # 10 EXTERNAL TOOTH LOCK - ZINC
41	INC IN KIT3008-2BLK	1	SWITCH BOX COVER LABEL FRONT
	<b>KIT2011BLK</b>		<b>HANDLE GRIP KIT - BLK</b>
42	INC IN KIT2011BLK	2	HANDLE GRIP -BLK
	<b>KIT2006</b>		<b>SAFETY SWITCH KIT</b>
43	INC IN KIT2006	1	SPRING 2LNG X .025 OD X .026
44	INC IN KIT2006	1	SAFETY SWITCH
	<b>KIT3011BLK</b>		<b>TRIGGER REPLACEMENT KIT</b>
45	INC IN KIT3011BLK	1	TRIGGER - BLK
46	INC IN KIT3011BLK	2	SPRING - TRIGGER
47	INC IN KIT3011BLK	2	ROLL PIN
	<b>KIT1005</b>		<b>REPLACEMENT SWITCH KIT - MAIN</b>
48	INC IN KIT1005	1	SWITCH
49	INC IN KIT1005	5	WASHER FLAT- ZINC
50	INC IN KIT1005	1	WASHER FLAT 5/16 USS - ZINC
51	INC IN KIT1005	1	WASHER 3/8 INTRNL TOOTH LOC-ZINC
52	INC IN KIT1005	1	SWITCH INSULATION

Parts list			
ITEM	PART NO.	QTY	DESCRIPTION
	<b>KIT3032</b>		<b>HANDLE ASSY LESS POWER CORD &amp; SWITCH BOX COVER</b>
63	INC IN KIT3032	1	HANDLE WDMT - BLK
	INC IN KIT3032	1	KIT2005 STRAIN RELIEF REPLACEMENT KIT
	INC IN KIT3032	1	KIT2033 HANDLE HARDWARE KIT
	INC IN KIT3032	1	KIT3011BLK TRIGGER REPLACEMENT KIT
	INC IN KIT3032	1	KIT2006 SAFETY SWITCH KIT
	INC IN KIT3032	1	KIT3009-1BLK CORD HOOK KIT (SQUARE)
	INC IN KIT3032	1	KIT1005 REPLACEMENT SWITCH KIT - MAIN
	INC IN KIT3032	1	KIT2026-1 HANDLE MOUNTING HWDR KIT
	INC IN KIT3032	1	KIT1043 IN-HANDLE CORD KIT
	<b>KIT2005</b>		<b>STRAIN RELIEF REPLACEMENT KIT</b>
53	INC IN KIT2005	1	STRAIN RELIEF
54	INC IN KIT2005	2	WASHER STRAIN RELIEF - ZINC
55	INC IN KIT2005	1	NUT CONDUIT 1/2
56	E0003-2	1	POWER CORD 14-3 SJT BLK THIN 50 FT CORD
	<b>KIT2033</b>		<b>HANDLE HARDWARE KIT</b>
57	INC IN KIT2033	1	WIRE NUT
39	INC IN KIT2033	4	SCREW 10-24 X .50 THIRD ROLL PHILL PAN ZINC
40	INC IN KIT2033	5	WASHER # 10 EXTERNAL TOOTH LOCK - ZINC
35	INC IN KIT2033	1	LOOP CLAMP
34	INC IN KIT2033	1	GROMMET IN HANDLE

## Handle Wiring

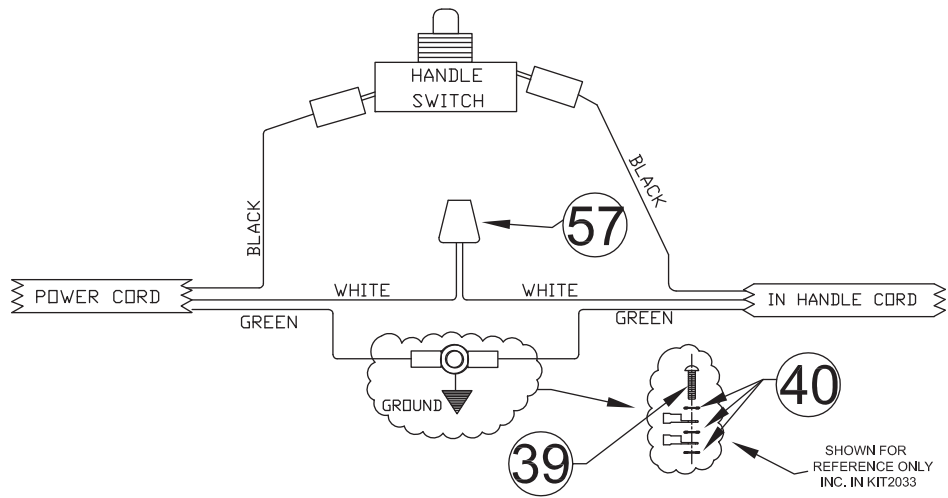





## Minuteman International Made Simple Commercial Limited Warranty

### REVISION Q EFFECTIVE 4/10/18

Minuteman International, Inc. warrants to the original purchaser/user that the product is free from defects in workmanship and materials under normal use. Minuteman will, at its option, repair or replace without charge, parts that fail under normal use and service when operated and maintained in accordance with the applicable operation and instruction manuals. All warranty claims must be submitted through and approved by factory authorized repair stations.

This warranty does not apply to normal wear, or to items whose life is dependent on their use and care, such as belts, cords, switches, hoses, rubber parts, brushes, electrical motor components or adjustments. Parts manufactured by Minuteman are covered by and subject to the warranties and/or guarantees of their manufacturers. Please contact Minuteman for procedures in warranty claims against these manufacturers.

**Special warning to purchaser** -- Use of replacement filters and/or pre-filters not manufactured by Minuteman or its designated licensees, will void all warranties expressed or implied. A potential health hazard exists without original equipment replacement.

All warranted items become the sole property of Minuteman or its original manufacturer, whichever the case may be.

Minuteman disclaims any implied warranty, including the warranty of merchantability and the warranty of fitness for a particular purpose. Minuteman assumes no responsibility for any special, incidental or consequential damages.

This limited warranty is applicable only in the U.S.A. and Canada, and is extended only to the original user/purchaser of this product. Customers outside the U.S.A. and Canada should contact their local distributor for export warranty policies. Minuteman is not responsible for costs or repairs performed by persons other than those specifically authorized by Minuteman. This warranty does not apply to damage from transportation, alterations by unauthorized persons, misuse or abuse of the equipment, use of non-compatible chemicals, or damage to property, or loss of income due to malfunctions of the product.

If a difficulty develops with this machine, you should contact the dealer from whom it was purchased.

This warranty gives you specific legal rights, and you may have other rights which vary from state to state. Some states do not allow the exclusion or limitation of special, incidental or consequential damages, or limitations on how long an implied warranty lasts, so the above exclusions and limitations may not apply to you.

Model	Parts	Labor	Poly	Travel**
Cord Electric Group	5yrs	3yrs	12yrs	90 days
Battery Auto Scrubbers (incl. on board charger)	5yrs	3yrs	12yrs	90 days
Battery and Manual Sweepers	3yrs	3yrs	12yrs	90 days

**Exceptions.....**

Model	Parts	Labor	Poly	Travel**
Port A Scrub, all models (incl. on board charger)	1yr	6months	12yrs	90 days
A3S Blower	1yr	1yr	0	0
Phenom Dual Motor Upright Vacuums	2yrs	2yrs	0	0
Explosion Proof Vacuum	1yr	1yr	0	0
Propane Burnisher	1yr	1yr	0	90 days
E14BQP and E14115 scrubber	1yr	1yr	12yrs	90 days
EZ-Mop	1yr	1yr	0	90 days
ROS-17	1yr	1yr	0	90 days
**Travel, 2 hours max				

<i>Stand-alone Battery Chargers:</i>	One year
<i>Replacement Parts:</i>	Ninety days
<i>Batteries:</i>	0-3 months full replacement, 4-12 months pro-rate
<i>Polypropylene Plastic Tanks:</i>	12yr warranty, no additional labor

# ***“Excellence Meets Clean”***

**Minuteman is a Full Line Manufacturer of Sweepers and Scrubbers,  
for Industrial Facilities.**